

1. K76 Incremental Optical Encoder (Through shaft)

1.1 Introduction:

K76 is a sturdy encoder with a large through hole that can output incremental and UVW signals.

It has a compact and durable structure and is widely used in servo motors and industrial automation fields.

1.2 Feature:

- Encoder external diameter $\varnothing 76.5\text{mm}$, thickness 37mm, diameter of shaft up to $\varnothing 30\text{mm}$, optional prior and rear shaft clamping;
- Ring locking mounting structure;
- Adopt non-contact photoelectric principle;
- Reverse polarity protection;
- Short circuit protection;
- Multiple electrical interfaces available;
- Resolution per turn up to 65536PPR.

1.3 Application:

Servo motor, subway, elevator, CNC and other automation control fields.

1.4 Connection:

- Radial cable (length 1M)

1.5 Protection:

IP50

1.6 Weight:

about 360g

K76-J
(BQ-clamping ring at prior)

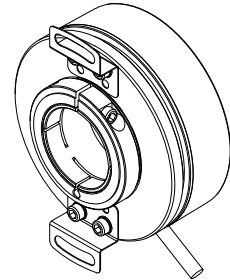

K76-J
(B-clamping ring at rear)

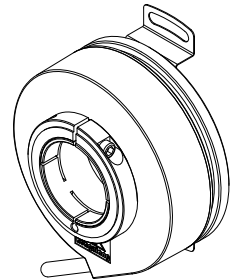

2. Model Selection Guide

2.1 Model composition(select parameters)

K76-	J	6	C	1024	BQ30			-	000
Product model series	Connection interface: J=Radial cable	Output phase: 1=A 2=A+B 3=A+B+Z 4=A+A+B+B 6=A+B+Z +A+B+Z	Electrical interface: N=OC(NPN) ^① NH=OC(NPN) ^② P=OC(PNP) ^① PH=OC(PNP) ^② V=Voltage ^② VL=Voltage ^① F=Push-pull ^① FH=Push-pull ^② C=TTL (DC5V,26LS31) E=HTL (DC8-30V) L=TTL (DC5V, 26C31)	Resolution PPR: 100; 200; 250; 300; 360; 400; 450; 500; 512; 600; 720; 800; 1000; 1024; 1200; 1800; 2000; 2048; 2500; 3000; 3600; 4000; 4096; 5000; 5000; 7200; 8000; 8192; 10000; 14400; 16000; 16384; 32000; 32768; 64000; 65536 For servo motor: Resolution/pole 1000/4, /6, /8; 1024/4, /6, /8; 2048/4, /6, /8; 2500/4, /6, /8; 4096/4, /6, /8; 5000/4, /6, /8; 8192/4, /6, /8;	Diameter of shaft: (Through) clamping ring at prior: BQ18= $\varnothing 18\text{mm}$ BQ20= $\varnothing 20\text{mm}$ BQ22= $\varnothing 22\text{mm}$ BQ25= $\varnothing 25\text{mm}$ BQ28= $\varnothing 28\text{mm}$ BQ30= $\varnothing 30\text{mm}$ clamping ring at rear: B18= $\varnothing 18\text{mm}$ B20= $\varnothing 20\text{mm}$ B22= $\varnothing 22\text{mm}$ B25= $\varnothing 25\text{mm}$ B28= $\varnothing 28\text{mm}$ B30= $\varnothing 30\text{mm}$	Supply voltage: Blank=DC5V H=DC8-30V	Special requirement: Blank=③	Management No.	

2.2 Note

- Z signal is low level active.
- Z signal is high level active.
- None indicated for IP50 and cable length of 1M, if need to change the length C+number, the longest is 100M (expressed by C100). For the specific length of use, pls refer to page 2 of the provision of output circuit.

3. Output Mode

3.1 Incremental signal

Electrical interface	Output circuit	Output wave form
<p>OC NPN open collector circuit</p>		<p>a.b.c.d=$\frac{T}{4} \pm 8$</p> <p>Phase A is ahead of B by $\frac{T}{4} \pm 8$, viewing from shaft end, direction is clockwise rotation. (See dimensional drawings)</p> <p>CW direction →</p> <p>Z signal is low level active</p>
<p>OC PNP open collector circuit</p>		<p>Z signal is high level active</p>
<p>Push-pull</p>		<p>Z signal is high level active</p>
<p>Voltage</p>		<p>Z signal is high level active</p>
<p>TTL (DC5V)</p> <p>HTL (DC8-30V)</p>		<p>a.b.c.d=$\frac{T}{4} \pm 8$</p> <p>Phase A is ahead of B by $\frac{T}{4} \pm 8$, viewing from shaft end, direction is clockwise rotation. (See dimensional drawings)</p> <p>CW direction →</p>

3.2 For servo motor(with UVW)

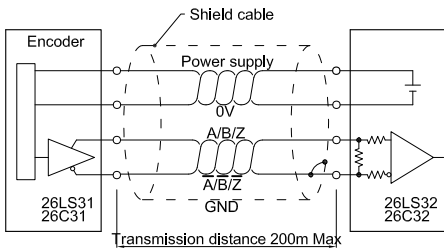
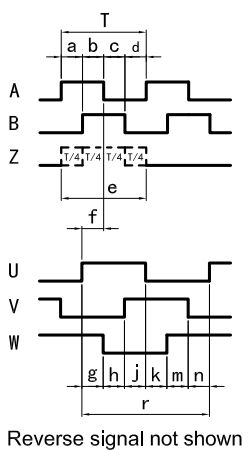
Electrical interface	Output circuit	Output wave form												
<p>TTL (DC5V)</p>		 <table border="1" data-bbox="1204 481 1444 638"> <thead> <tr> <th>pole</th> <th>g,h,j,k,m,n</th> <th>r</th> </tr> </thead> <tbody> <tr> <td>4</td> <td>30±1°</td> <td>180°</td> </tr> <tr> <td>6</td> <td>20±1°</td> <td>120°</td> </tr> <tr> <td>8</td> <td>15±1°</td> <td>90°</td> </tr> </tbody> </table> <p> $a,b,c,d = \frac{T}{4} \pm \frac{T}{8}$ $e = T \pm \frac{T}{2}$ f: center of phase Z to rise point of phase U, that is ±1° </p> <p>CCW direction →</p> <p>Viewed from shaft end when installing. (See dimensional drawings)</p>	pole	g,h,j,k,m,n	r	4	30±1°	180°	6	20±1°	120°	8	15±1°	90°
pole	g,h,j,k,m,n	r												
4	30±1°	180°												
6	20±1°	120°												
8	15±1°	90°												

4. Electrical Parameters

Parameter Item	Output type	OC	Voltage	Push-pull	TTL	HTL	
Supply voltage		DC+5V±5%; DC8V-30V±5%			DC+5V±5%	DC8-30V±5%	
Consumption current		100mA Max			120mA Max		
Allowable ripple		≤3%rms					
Top response frequency		100KHz			300KHz	500KHz	
Output capacity	Output current	Input	≤30mA	Load resistance 2.2K	≤30mA	≤±20mA	≤±50mA
		Output	—		≤10mA		
	Output voltage	"H"	—	—	≥[(Supply voltage) -2.5V]	≥2.5V	≥V _{cc} -3 V _{Dc}
		"L"	≤0.4V	≤0.7V(less than 20mA)	≤0.4V(30mA)	≤0.5V	≤ 1V V _{Dc}
Load voltage		≤DC30V	—		—		
Rise & Fall time		Less than 2us(cable length: 2m)			Less than 1us (Cable length: 2m)	≤100ns	
Insulation strength		AC500V 60s					
Insulation resistance		10MΩ					
Mark to space ratio		45% to 55%					
Reverse polarity protection		✓					
Short-circuit protection		—			✓①		
Phase shift between A & B		90°±10° (frequency in low speed)					
		90°±20° (frequency in high speed)					
GND		Not connect to encoder					

① Short-circuit to another channel or GND permitted for max.30s.

5. Mechanical Parameters

Diameter of shaft	Ø18mm; Ø20mm; Ø22mm; Ø25mm; Ø28mm; Ø30mm available
Shaft material	Stainless steel
Starting torque	Less than 80×10^{-3} N·m
Inertia moment	Less than 100×10^{-6} kg·m ²
Permissible movement static	±0.2mm (radial) ; ±0.3mm (axial)
Permissible movement dynamic	±0.05mm (radial) ; ±0.1mm (axial)
Shaft load	Radial 70N; Axial 50N
Slew speed	≤3000 rpm
Housing material	Aluminum alloy
Weight	Approx.360g

6. Environmental Parameters

Shell protection grade	IP50
Permissible relative humidity	Operating and storage: 35~85%RH(noncondensing)
Operating temperature range	Operating: -20~+85°C(repeatable winding cable: -10°C)
Storage temperature range	Storage: -25~+90°C
Resistance to shocks	1960m/s ² , 11ms three times for X,Y,Z direction individually
Frequency range to resistance to vibrations	Amplitude 0.75mm, 5~55Hz, 2h for X,Y,Z direction individually

7. Wiring table

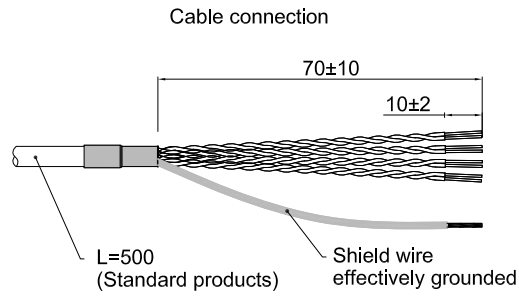

7.1 OC/Voltage/Push-pull (Table 1)

	Supply voltage		Incremental signal		
Wire color	Red	Black	White	Green	Yellow
Function	Up	0V	A	B	Z

7.2 TTL/HTL (Table 2)

	Supply voltage		Incremental signal					
Wire color	Red	Black	White	White/BK	Green	Green/BK	Yellow	Yellow/BK
Function	Up	0V	A+	A-	B+	B-	Z+	Z-
Twisted-paired cable								

7.3 For servo motor (Table 3)

	Supply voltage		Incremental signal											
Wire color	Red	Black	White	White/BK	Green	Green/BK	Yellow	Yellow/BK	Blue	Blue/BK	Grey	Grey/BK	Pink	Pink/BK
Function	Up	0V	A+	A-	B+	B-	Z+	Z-	U+	U-	V+	V-	W+	W-
Twisted-paired cable														

Up=Supply voltage.
Shield wire is not connected to the internal circuit of encoder.

8. Basic Dimensions

8.1 Clamping ring at prior(BQ)

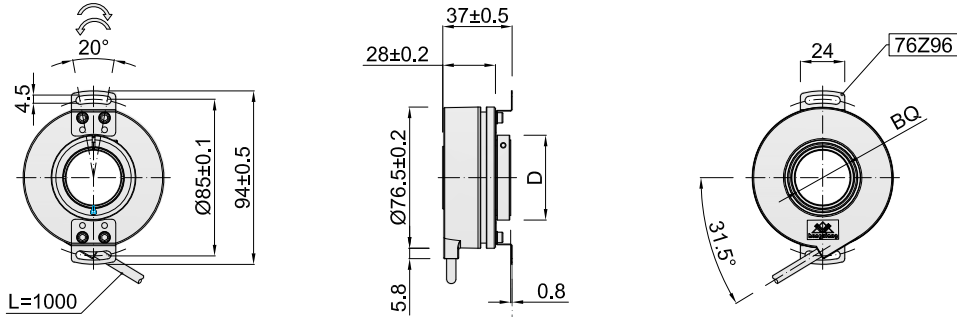

BQ(shaft)	D
Ø18 ^{G7} (+0.028/+0.007)	Ø36
Ø20 ^{G7} (+0.028/+0.007)	Ø36
Ø22 ^{G7} (+0.028/+0.007)	Ø41
Ø25 ^{G7} (+0.028/+0.007)	Ø41
Ø28 ^{G7} (+0.028/+0.007)	Ø46
Ø30 ^{G7} (+0.028/+0.007)	Ø46

8.2 Clamping ring at rear(B)

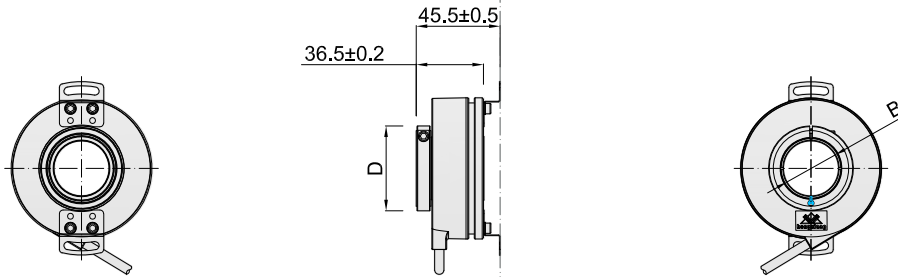

B(shaft)	D
Ø18 ^{G7} (+0.028/+0.007)	Ø36
Ø20 ^{G7} (+0.028/+0.007)	Ø36
Ø22 ^{G7} (+0.028/+0.007)	Ø41
Ø25 ^{G7} (+0.028/+0.007)	Ø41
Ø28 ^{G7} (+0.028/+0.007)	Ø46
Ø30 ^{G7} (+0.028/+0.007)	Ø46

8.3 Mounting shaft requirements

d
Ø18 _{g6} (-0.007/-0.020)
Ø20 _{g6} (-0.007/-0.020)
Ø22 _{g6} (-0.007/-0.020)
Ø25 _{g6} (-0.007/-0.020)
Ø28 _{g6} (-0.007/-0.020)
Ø30 _{g6} (-0.007/-0.020)

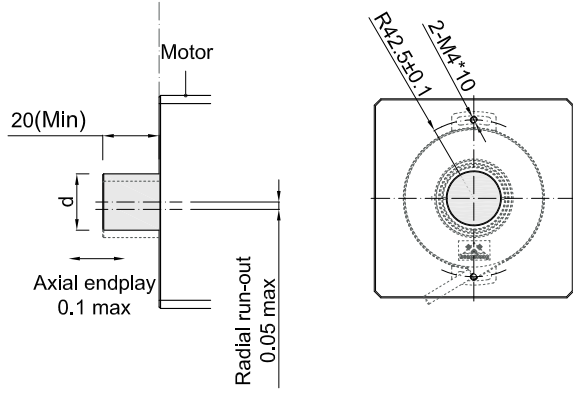

Mounting screws
Inner hexagon bolt +flat washer Specification: M4*8 Material: stainless steel Quantity: 2

Unit: mm

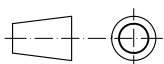

76Z96 = Spring plate (other mounting spring plates are available, pls refer to page 9)

- = Direction of shaft rotation for incremental signal output
- = Direction of shaft rotation for servo motor-specific signal output

About vibration

Vibration act on encoder always cause wrong pulse, so we should pay attention to working place. More pulse per revolution, narrower groovy spacing of grating, more effect to encoder by vibration, when rev is low or stop, vibration act on shaft or main body would cause grating vibrating, so encoder might make wrong pulse.

9. Accessories (Spring plate options)

<p>76Z96 (Standard)</p>	<p>76Z96 Spring plate installation method I</p>
<p>76Z96 (Standard)</p>	<p>76Z96 Spring plate installation method II</p>
<p>76T69 (Optional)</p>	